

Device description

PX723 is a dedicated keypad for cooperation with the controllers PX710 / PX710+ and PX340 / PX340+. It is possible to create the system of additional inputs for the controllers PX710 / PX710+ and PX340 / PX340+, which include the devices PX723 and PX734.

PX723 expands the system by 8 digital inputs in the form of touch buttons and PX734 expands it by one analogue input and one digital input (the movement sensor and the analogue light sensor). Both devices are connected to the PX340 / PX710 controllers with a connector, which is the Keyboard Hub PX725. In the PX710+ and PX340+ controllers, the additional Keyboard Hub PX725 device is not required.

Each button of PX723 has a LED indicator with adjustable brightness. Its state is controlled by the controller, and the configuration is carried out with the use of the program PxDesigner (available for free download on producer's website). Moreover, pressing the button can be signaled with the short acoustic signal.

It is possible to connect 64 devices (max. 32 per one line) and they should be connected in series.

The front panel is made with tempered glass, and the housing of PX723 enables an easy assembly in the standard double electrical box.

drawing of the keypad without the mounting plate

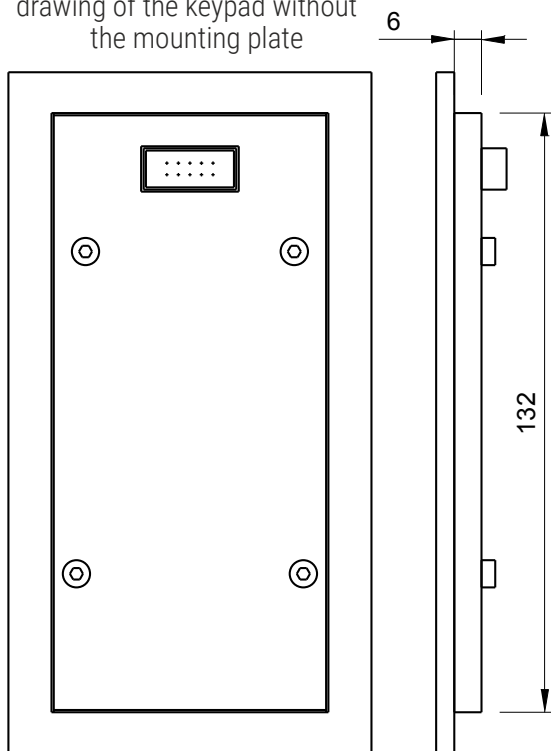

drawing of the keypad with the mounting plate

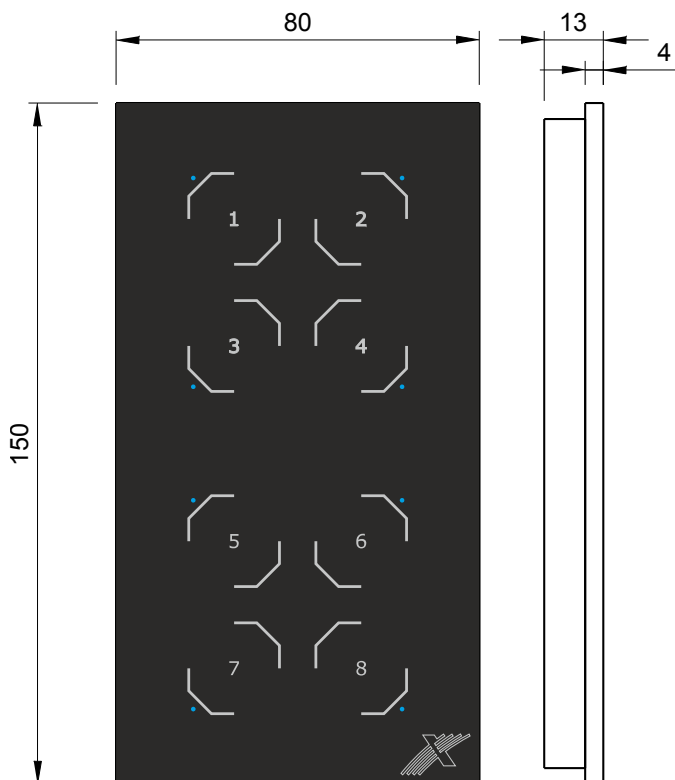

drawing the mounting plate

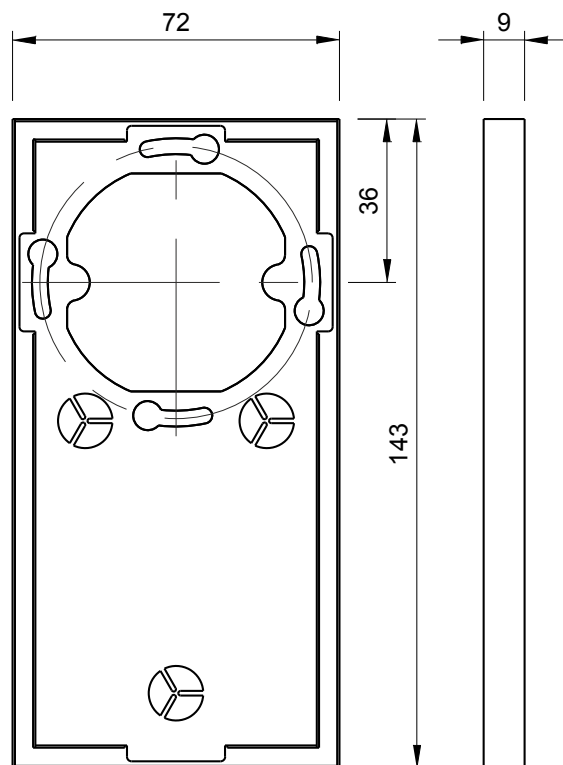

Connection diagram

a) PX723 connection to the PX340 / PX710 controller

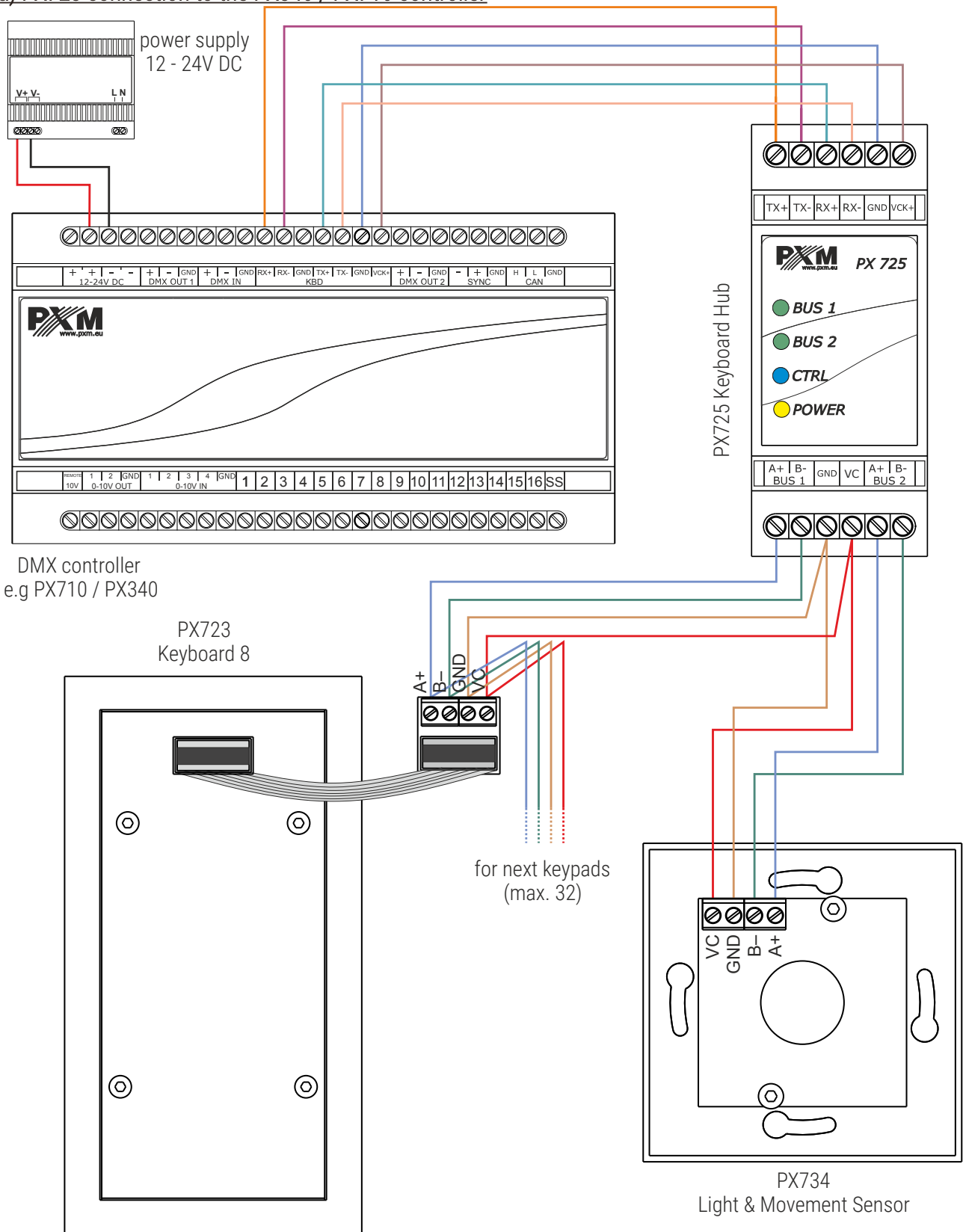

DMX controller
e.g PX710 / PX340

PX723
Keyboard 8

for next keypads
(max. 32)

PX734
Light & Movement Sensor

b) PX723 connection to the PX340+ / PX710+ controller

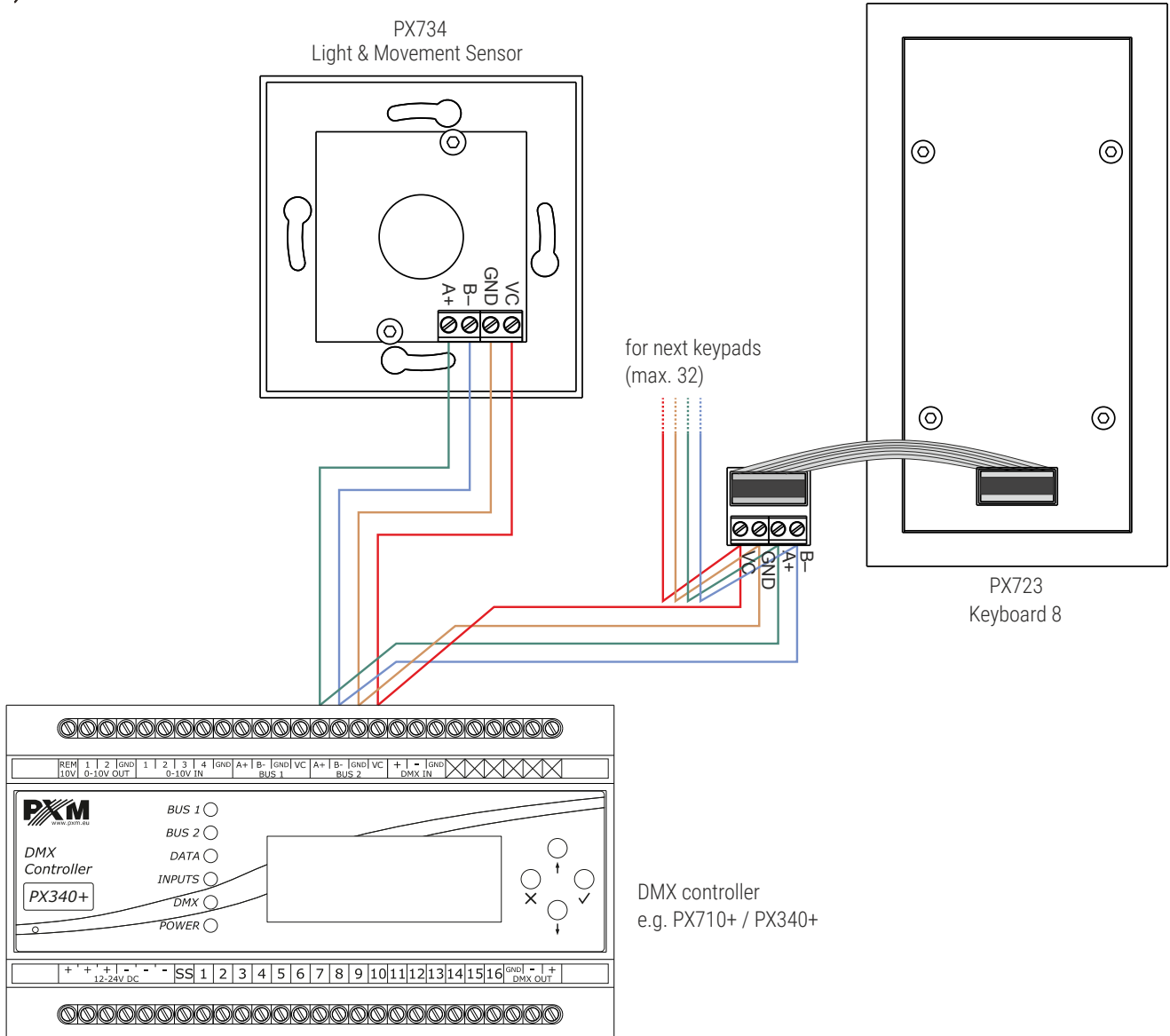

Technical data

type	PX723
power supply	PX725 or PX710+ / PX340+
number of the buttons	8
LED diodes	8
cooperation with the controllers	PX710, PX340, PX710+, PX340+
method of communication with the controller	PX725 Keyboard Hub / directly from PX710+ or PX340+
maximum number of the devices	64 (max. 32 for one line)
method of programming	with the use of PxDesigner
weight	0.25kg
dimensions	width: 80mm height: 150mm depth: 13mm