



PRO LIGHTING EQUIPMENT

LD-360 Users Manual

LD360 MPX
LD360 MPX HP

Document number:
21-1044D

Software Version 1.0
February 2, 2000

Leprecon, LLC
10087 Industrial Drive
P.O. Box 430
Hamburg, MI 48139 USA
810-231-9373
FAX 810-231-1631

Introduction

The Leprecon LD360 MPX dimmer was designed as high-quality, low maintenance dimmer. Reliability is enhanced by the use of dual SCR's and magnetic circuit breakers. With proper use, the LD360 MPX should provide years of trouble-free service. Please read and observe instructions for safe and reliable operation.

Illustration

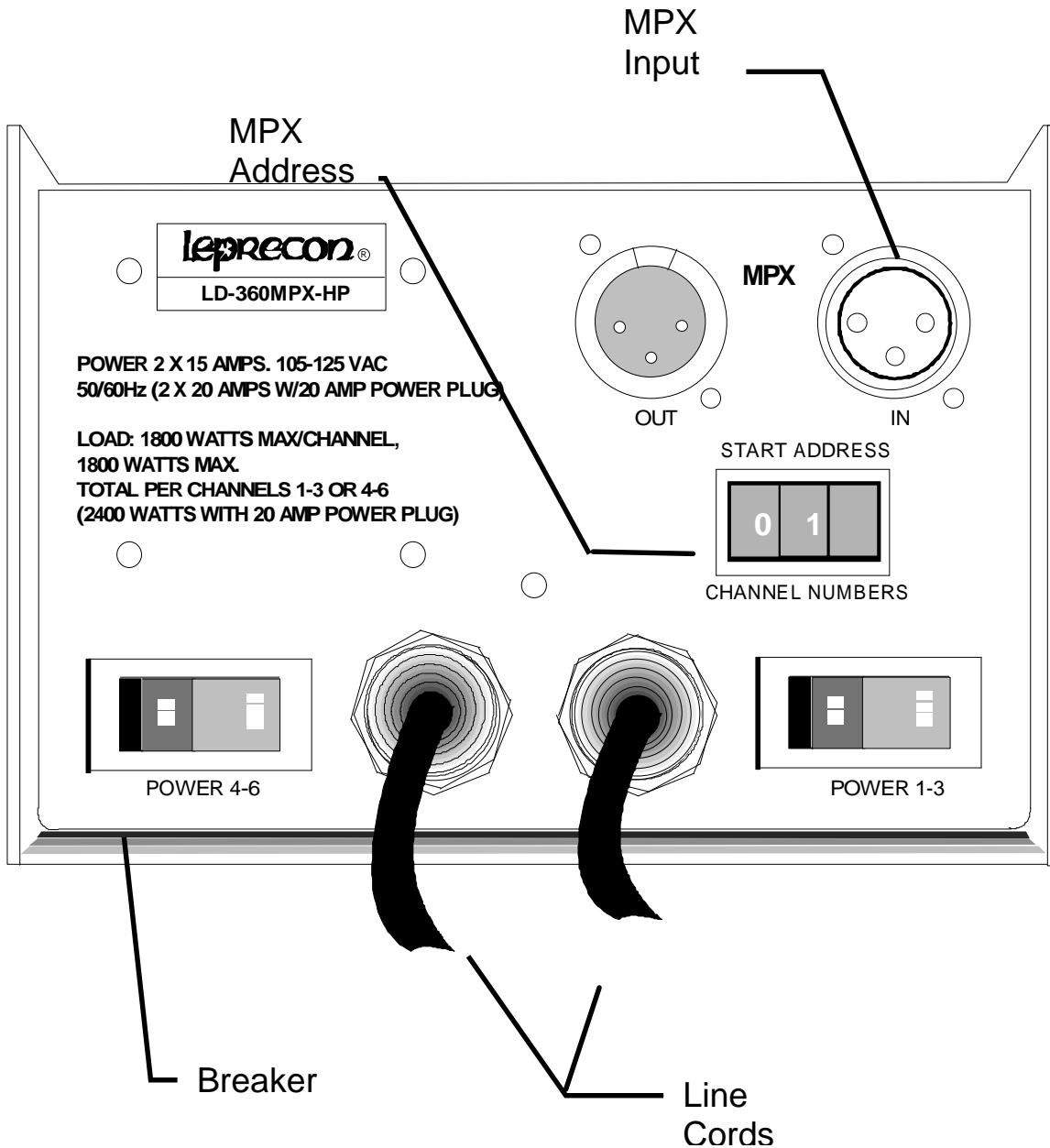

Specifications

Power Capacity

The LD360 MPX is unique in the market of small portable dimmers. A single breaker is used on the pack instead of individual fuses per each channel. As a result, the limits of the dimmer are *pack* limits, not channel limits. The following guidelines should be followed:

LD360 MPX:

Pack Limit: 15 Amps
20 Amps with approved plug.

LD360 MPX-HP

Pack Limit: 15 Amps per line cord.

As indicated, the total pack power of the LD360 MPX can be increased to 20 amps by changing the factory supplied 15 amp power plug to a type approved for the higher power. Some of the choices are:

<u>Plug</u>	<u>Mating Socket</u>	<u>Type</u>
Nema 5-20P Hubbel 5364VY Hubbel 5366C	Nema 5-20S Hubbel 5369VY Hubbel 5369C	"Tee Blade"
Nema L5-20P Hubbel 2311VY Hubbel 2311	Nema L5-20S Hubbel 2313VY Hubbel 2311	Twist Lock

Control input

The LD360 MPX uses a multiplexed control signal that is common in the industry, The Microplex signal is carried on standard 3 pin XLR (microphone) cable, allowing the use of audio cables for dimmer connection. Simply connect a 3-pin microphone cable between the console being used and the LD360 MPX dimmer control input.

For convenience, two connectors are provided on the LD360MPX. This allows easy connection to additional dimmer packs.

Installation and Use

Mounting

The LD360 dimmers are passively cooled, using no internal fans or other noisy cooling devices. The heat generated by the dimmer is dissipated by the metal chassis. For this reason, it is necessary to mount the dimmer so that air is free to circulate around the dimmer. The dimmer should be mounted with at least 12 inches of clearance between the dimmer and any ceiling or obstruction above the dimmer that would block air circulation.

Power Connection

Leprecon LD360 series dimmers are supplied with line cords with standard Edison plugs attached. The LD360 dimmer can present up to a 20 Amp load per line cord; use of extension cords for power is not recommended. The LD360 should be connected to a service capable of supplying 20 amps and protected by a properly sized circuit breaker.

If you have any questions about the suitability of the power circuit that you intend to use with the LD360 dimmer, consult with a qualified electrician.

Load Connection

The LD360 MPX dimmer is provided with standard duplex outlets. The capacity of these outlets is 15 amps each. Lamp loads are plugged directly into the outlets on the body of the dimmer.

Address Selection

The LD360 MPX dimmer can be set to respond to any control channel from 1 to 99. Two thumbwheel switches are provided for easy address setting. Just set the switches to read the correct start address. The address shown on the switches is the address for the first channel of the dimmer. Examples follow:

Start Address:

1
2
5

Pack Range

channels 1-6
channels 2-7
channels 5-10

Service

Service policy

The LD360MPX is designed for a long, trouble free life. If you suspect that you have a dimmer problem, the first step is to check all other system components and connections. The easiest test is to substitute a known good dimmer in place of the suspected unit. Make sure that the address switches are set to the same address.

Specific problems and solutions are listed below:

<u>Problem</u>	<u>Indication</u>	<u>Solution</u>
no power	breaker not lighted	check and repair power feed
shorted load	breaker trips	repair instrument
no signal	no lights	swap board to diagnose, check control cable
SCR failure	channel stuck at full	refer to service center
address out of range	channels drift to 100%	re-set address switches
Overload	breaker trips	check wattage of loads

If a problem is verified in the dimmer pack, contact your Leprecon dealer for service. Because of the high voltages present inside of the dimmer, it is important that only qualified personnel perform all service. Substandard repairs can create a dangerous, potentially life-threatening situation.

Service Information

See warranty card for specific warranty information.

Our service department must first authorize any return to the factory. Do not return any equipment without calling for an authorization number. The Leprecon service department may be reached at 810 231 9373 during business hours, or a message may be left after hours. Our fax number is 810 231 1631.

Spare parts list

<u>Description</u>	<u>Order Number</u>
Line Cord	19-9007
Strain Relief	18-2013
Circuit Breaker	60-06-0005
IC, Opto Triac MOC3020	03-3008
Address Switch Assembly	40-06-0002
Connector, XLR Female	07-1125
Connector, XLR Male	07-1137
Duplex Outlet	07-3018
SCR, 20 Amp	03-3002
Metal Oxide Varistor	15-9005
Transformer, ST4-36	10-0024

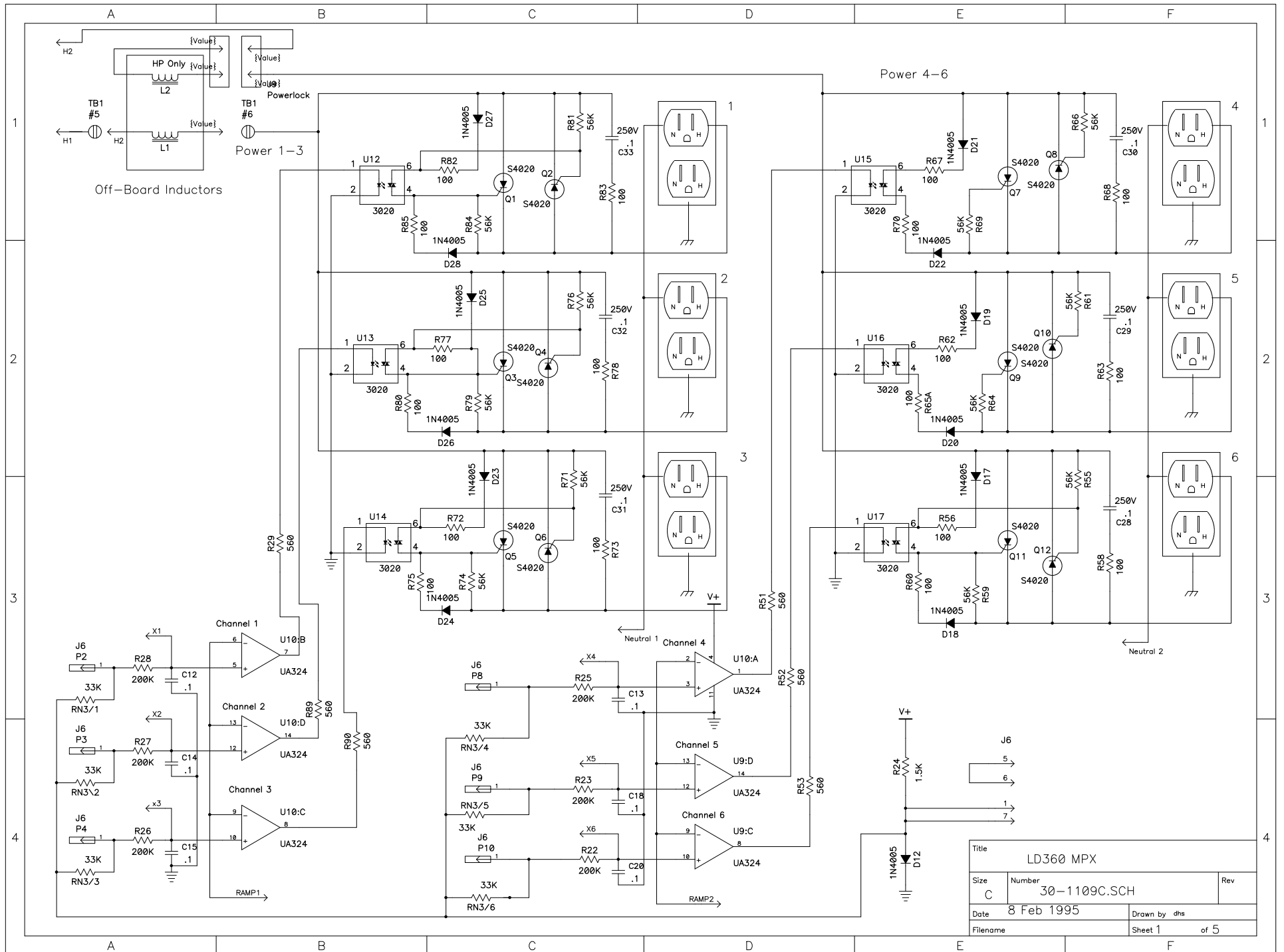

Title			LD360 MPX		
Size	Number			Rev	
C	30-1109C.SCH				
Date	8 Feb 1995	Drawn by	dns		
Filename	Sheet 1	of 5			

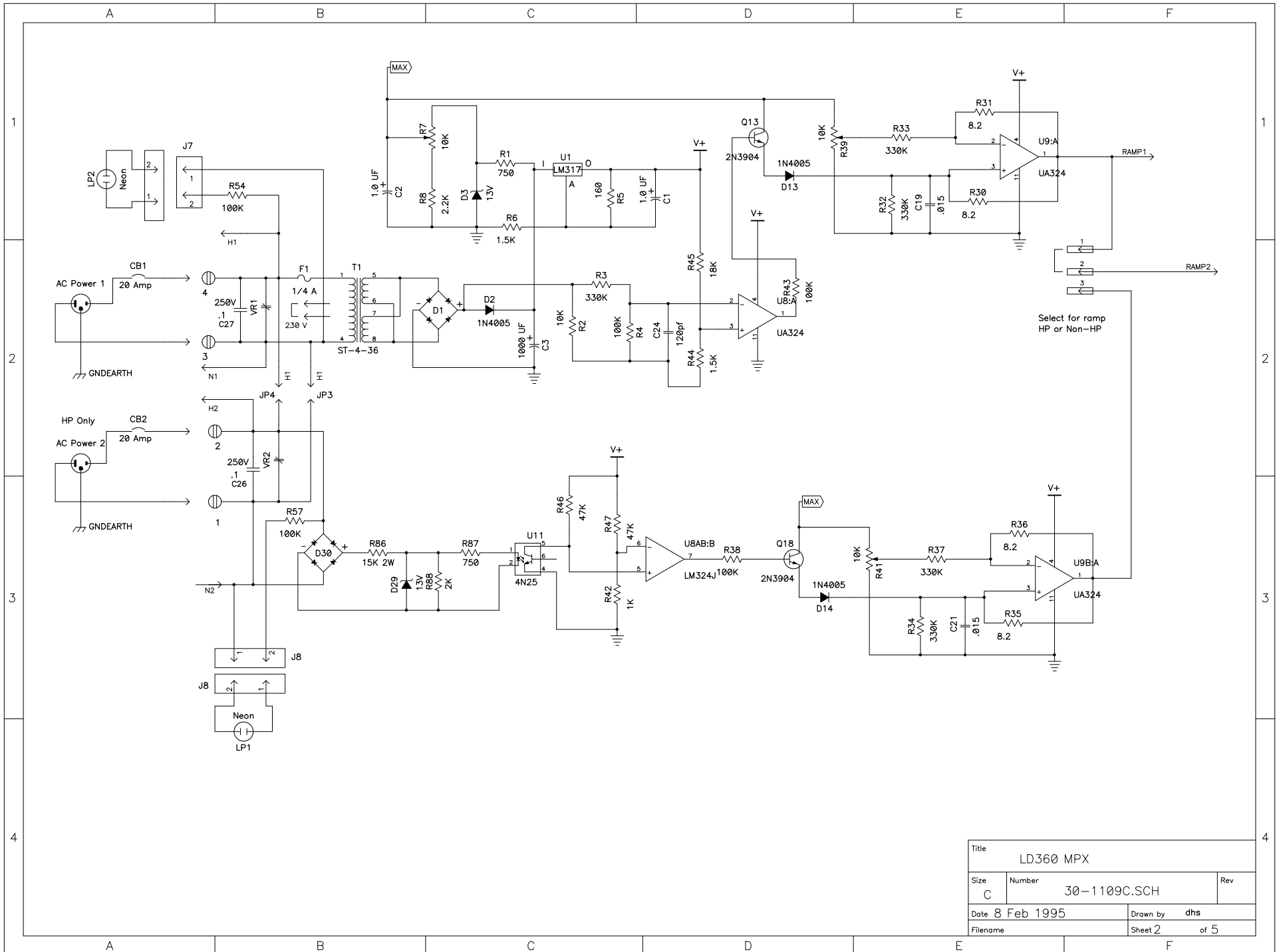

Title			LD360 MPX		
Size	Number				Rev
C	30-1109C.SCH				
Date 8 Feb 1995		Drawn by dhs			
Filename		Sheet 2		of 5	

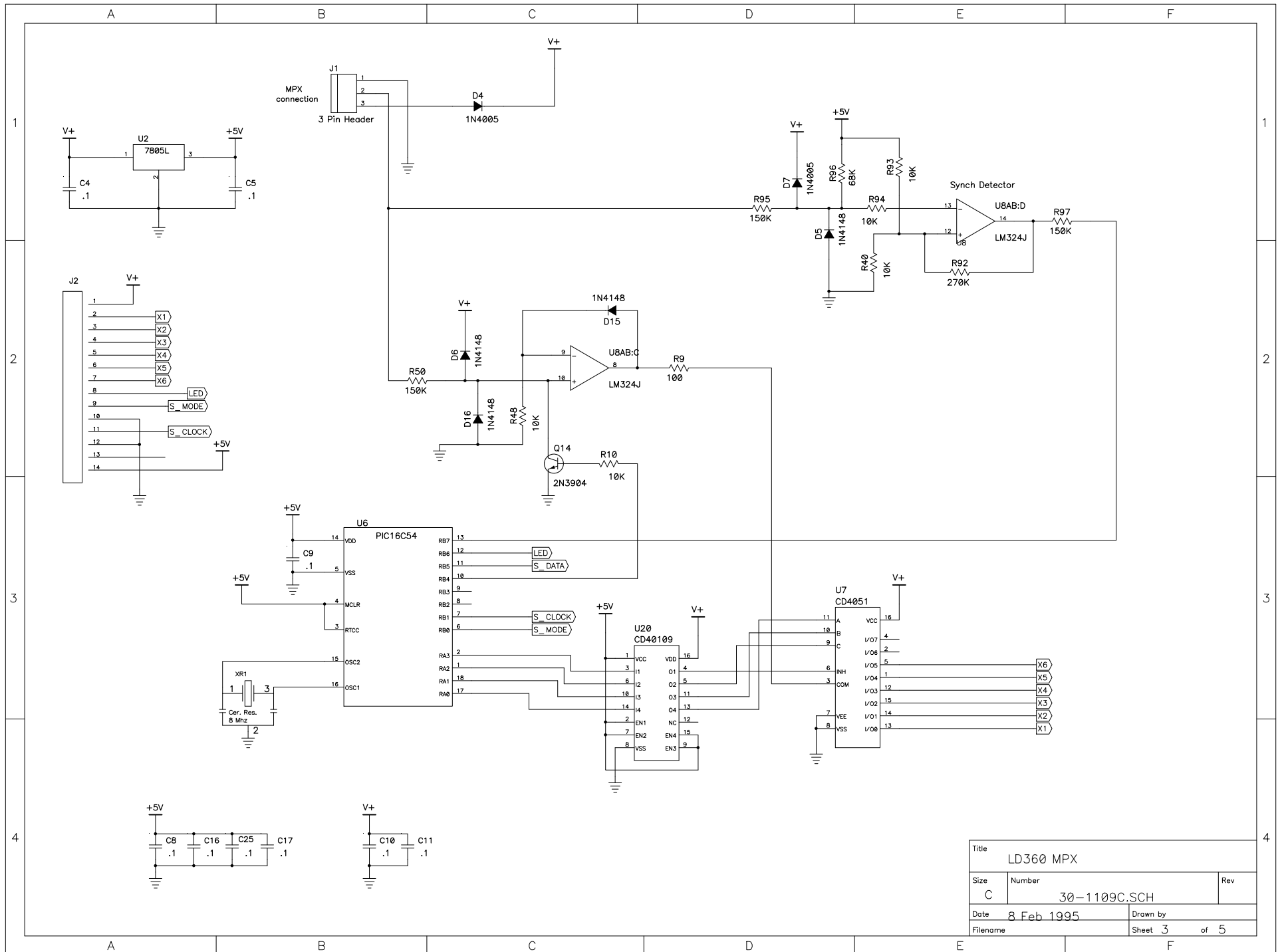

Title			LD360 MPX		
Size	Number			Rev	
C	30-1109C.SCH				
Date	8 Feb 1995		Drawn by		
Filename			Sheet	3	of 5

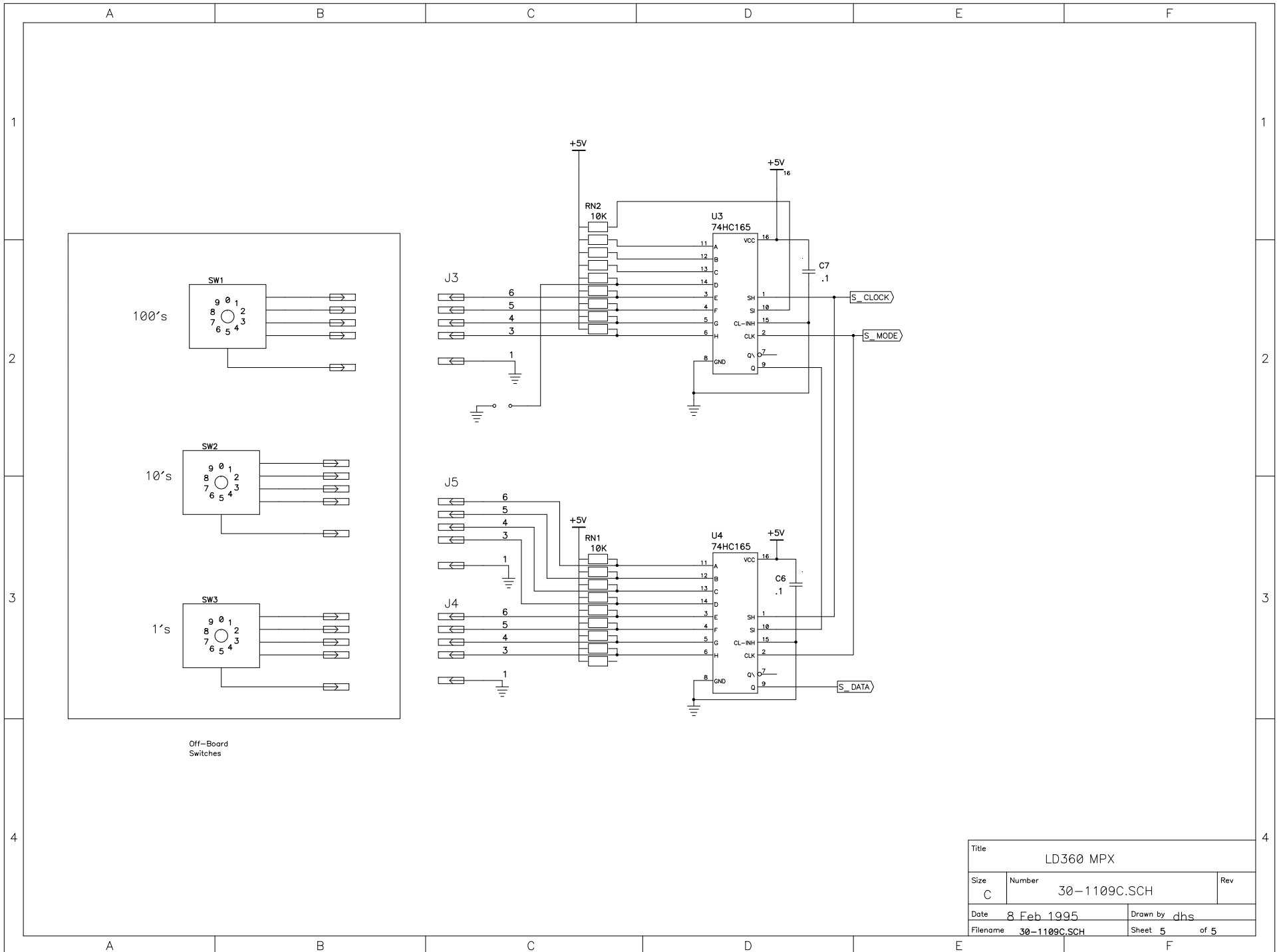

Off-Board
Switches

Title			LD360 MPX		
Size	Number	Rev			
C	30-1109C.SCH				
Date	8 Feb 1995	Drawn by		dhs	
Filename	30-1109C.SCH	Sheet		5 of 5	