

PX710S+

DMX Controller Slave

User manual



Table of Contents

1 Description.....	4
2 Safety conditions.....	5
3 Connectors and control elements.....	6
4 Screen and buttons.....	7
4.1 Navigating the menu.....	7
4.2 Main window.....	8
4.3 Controller status.....	8
4.3.1 DMX output.....	9
4.3.2 Running scenes.....	9
4.3.3 Running programs.....	10
4.4 Clock.....	10
4.5 Channel test.....	11
4.6 Screen settings.....	12
4.6.1 PIN protection.....	13
4.7 Information about the driver.....	14
4.8 Network settings.....	14
4.9 Restart.....	15
5 Network settings of the controller.....	16
5.1 Change of the computer network configuration.....	18
5.2 Connecting controller directly to the PC.....	21
5.3 Connecting the controller using a router.....	21
5.3.1 Automatic addressing.....	22
5.3.2 Static addressing.....	23
6 Logging into the controller.....	23
6.1 Logging in to the controller in the local network.....	24
6.2 Remote logging (external network).....	24
6.2.1 Logging in via the PxDesigner application.....	26
7 Software installation.....	31
7.1 Windows®.....	31
8 Controller configuration.....	33
9 Live mode.....	33
10 Indication lights.....	34

10.1 RESET button operation and restoring default settings.....	35
10.2 Core mode, FTP support.....	36
11 Connection scheme.....	37
12 Dimensions.....	38
13 Technical data.....	38

Manufacturer reserves the right to make modifications in order to improve device operation.

PXM Marek Żupnik sp.k.
Podłęże 654
32-003 Podłęże
BDO register number 000005972

tel. +48 12 385 83 06
mail: info@pxm.pl
www.pxm.pl

Rev.1-0
22.02.2022

1 Description

The PX710S+ DMX Controller is an advanced device that allows you to extend the number of DMX lines by working with the PX710M+ controller.

The device has 2 DMX output lines (1024 channels) and allows to run multiple configuration items simultaneously. The installation can be extended by 7 PX710S+ devices. This allows to obtain up to 8192 DMX channels (PX710M+ and 7 PX710S+ devices).

An advanced PC application PxDesigner (Windows®) allows for programming the device. The application has a built-in library of devices that can be distributed on a graphic project, which facilitates the creation of complex light shows, including ones that are synchronized with sound.

The PX710S+ has a screen and buttons, so user can read the basic operating parameters.

The controller can be used to create up to 16 users with different access rights. There is an option to remotely log on to the controller from the external network.

2 Safety conditions

PX710S+ DMX Controller Slave is a device powered with safe voltage 12 – 24V DC, however, during its installation and use the following rules must be strictly observed:

1. The device can be connected to 12 – 24V DC (stabilized voltage) with current-carrying capacity compatible with technical data.
2. All the conductors should be protected against mechanical and thermal damage.
3. In case of damage to a conductor, it should be replaced with a conductor of the same technical parameters.
4. Connection of DMX signal can be made with a shielded conductor only.
5. All repairs, connecting and disconnecting of cables can only be made with cut off power supply.
6. The device should be strictly protected against contact with water and other liquids.
7. All sudden shocks, particularly dropping should be avoided.
8. The device cannot be turned on in places with humidity exceeding 90%.
9. The device cannot be used in places with temperature lower than +2°C or higher then +40°C.
10. Clean with damp cloth only.

3 Connectors and control elements

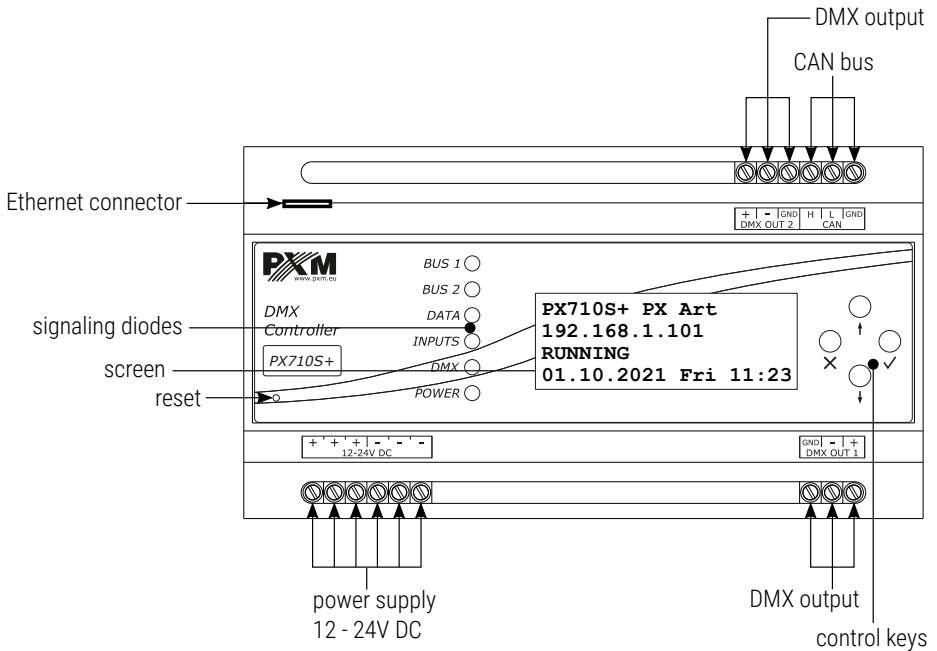

4 Screen and buttons

4.1 Navigating the menu

- ✕ (escape) - allows to exit the parameter being programmed without saving any changes or to move to a higher menu level
- ↓ (next) - scrolls the menu down or reduces the values to be set
- ↑ (prev) - scrolls the menu up or increases the values to be set
- ✓ (enter) - allows to enter the programming mode and confirm the values set

The ► symbol indicates the currently selected parameter, which will be entered after clicking the *enter* button. The symbols ▼ and ▲ inform the user that it is possible to scroll the screen and display other options (with the *prev* or *next* buttons).

The currently edited parameter is marked with angle brackets *<parameter>*.

4.2 Main window

The start screen, which is visible after starting the device, contains: model and serial number of the device, its current IP address, status as well as date and time on the device.

PX710S+ 21320345
192.168.1.101
RUNNING
01.10.2021 Fri 11:23

Possible statuses are:

- **RUNNING** – normal device operation,
- **STOP** – the operation of the device is suspended (e.g. due to the lack of configuration).

4.3 Controller status

In the **CONTROLLER STATUS** tab you can preview:

- DMX outputs,
- running scenes,
- running programs.

4.3.1 DMX output

In the **DMX OUTPUT** menu, in the **CONTROLLER STATUS** tab, you can read the DMX control level values on each channel. The information is displayed 12 channels per screen.

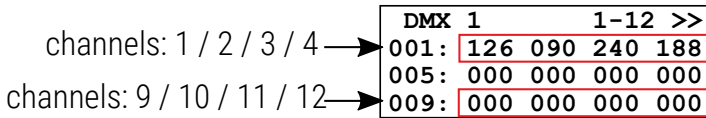
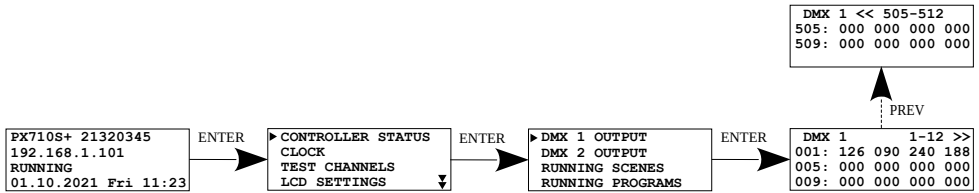

4.3.2 Running scenes

In the **RUNNING SCENES** menu on the **CONTROLLER STATUS** tab you can see which scenes are currently running.

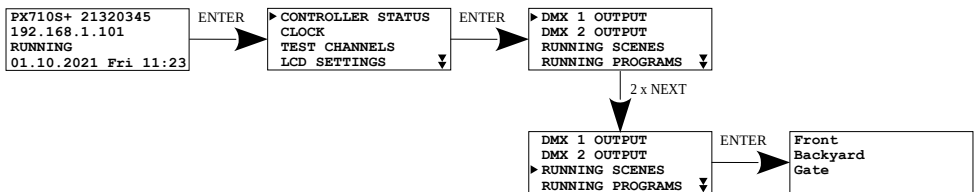

No Running Scenes is displayed on the screen when no scene is running.

The list is refreshed when you enter the scenes preview.

4.3.3 Running programs

In the **RUNNING PROGRAMS** menu in the **CONTROLLER STATUS** tab you can view which programs are currently running.

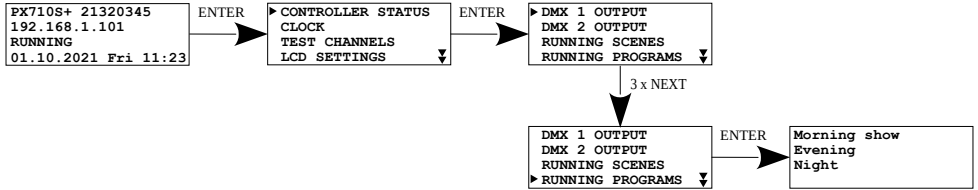

No Running Programs is displayed on the screen when no program is running.

The list is refreshed when you enter the programs preview.

4.4 Clock

In the **CLOCK** menu, you can read the current date, day of the week and time, in addition, the controller displays the **SUNRISE** and **SUNSET** times of the sun.

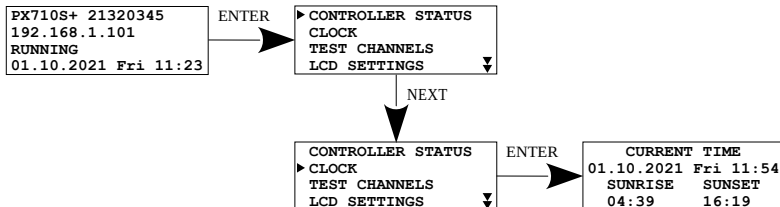

4.5 Channel test

The **TEST CHANNELS** allows to drive **ALL** channels to the maximum value – 255. It is also possible to control individual channels. This option can be useful for testing the connection on the DMX line between the controller and the signal receiver.

Press the *enter* button to switch the DMX test signal on and off, while the *prev* and *next* buttons change the DMX channels or select the **ALL** option.

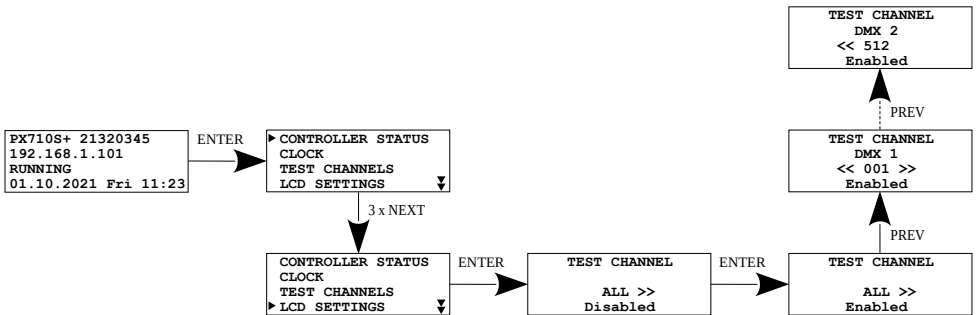

NOTE! When you exit this menu, signal testing automatically changes to the *Disabled* trim.

4.6 Screen settings

LCD SETTINGS allows to change the brightness of the display, the values are expressed as a percentage (0%, 25%, 50%, 75%, 100%). In this menu, the user can enable the **DARK MODE** option, i.e. turning off the screen backlight after ~15 seconds of inactivity.

The device will continue to work without interfering with other parameters. To restore the backlight, press any key.

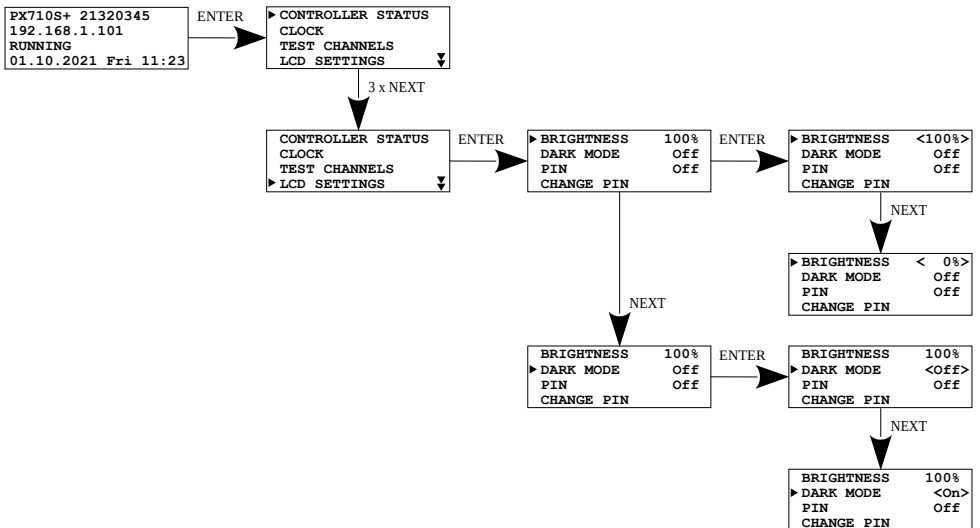

NOTE! Active **DARK MODE** turns off the backlight only on the main window.

4.6.1 PIN protection

The device can be protected with a code, the function is activated in the **LCD SETTINGS** menu. Change the **PIN** option to **On**. The default PIN is **0000**.

To lock the device, press and hold the **esc** button in the home screen. When the PIN code protection function is active, the padlock icon is displayed on the display in the main window. Padlock open – device not locked, padlock locked – device locked.

Unlocking the device is done by pressing the **enter** button and entering the PIN code using the **prev** and **next** buttons, pressing the **enter** button between consecutive digits.

To change the PIN, select **CHANGE PIN** in the menu, first enter the old PIN, and then enter the new one and confirm the changes by selecting **Accept**.

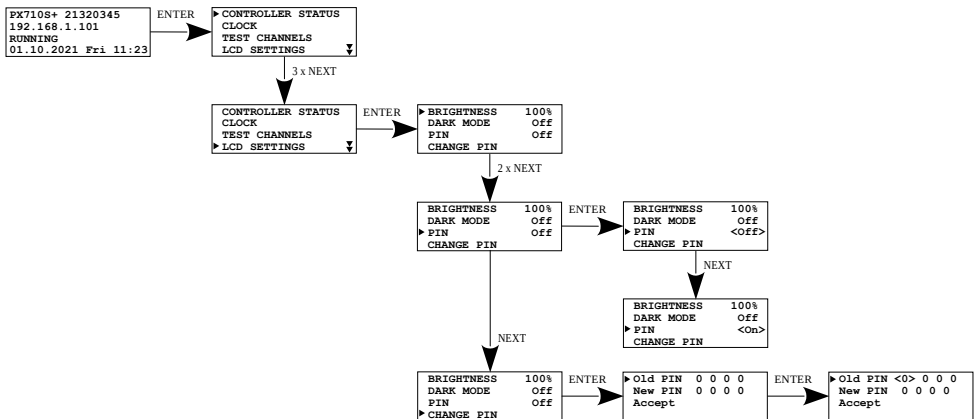

NOTE! After activating the function of securing the device with a PIN code, it is recommended to change the PIN from the default one to the one defined by the user.

4.7 Information about the driver

Information about the controller are available in the *CONTROLLER INFO* tab, you can read:

- serial number and MAC,
- firmware version.

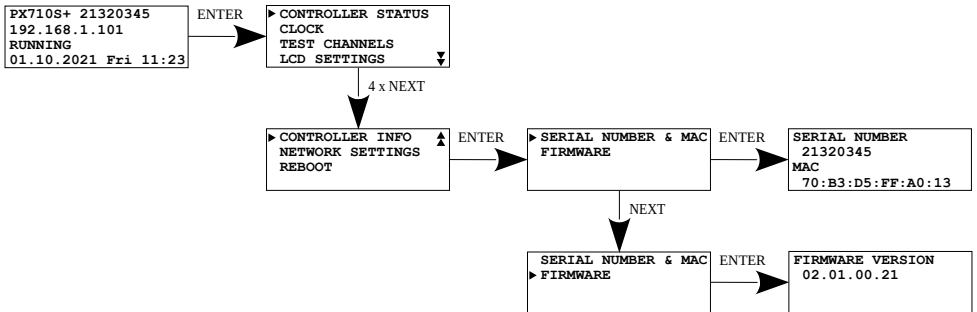

4.8 Network settings

In the controller on the screen, the user can check the IP address, network mask, default gateway and check whether DHCP is enabled.

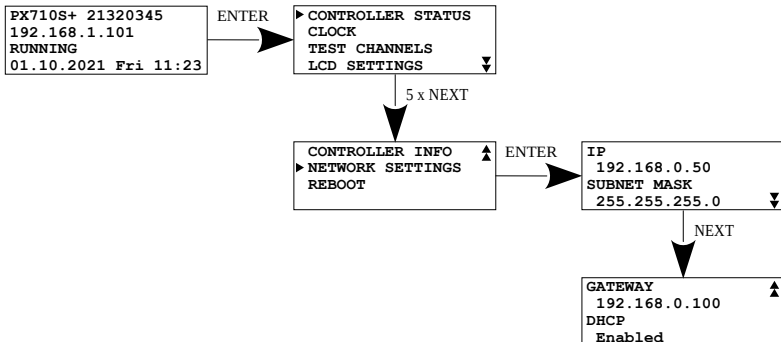

4.9 Restart

The **REBOOT** tab in the menu includes the following options:

- **REBOOT** – restarting the device,
- **FACTORY DEFAULTS** – factory reset:
 - IP: 192.168.0.50
 - Mask: 255.255.255.0
 - Device name: Px710S+ [serial number]
 - ADMIN account password: [serial number]
 - Remove configuration – configuration can still be downloaded in PxDesigner
- **RESET NETWORK** – reset network settings:
 - IP: 192.168.0.50
 - Mask: 255.255.255.0
 - Gateway: 192.168.0.100
 - DHCP: On
- **LOGOUT ALL USERS** – logout of all users currently connected to the controller

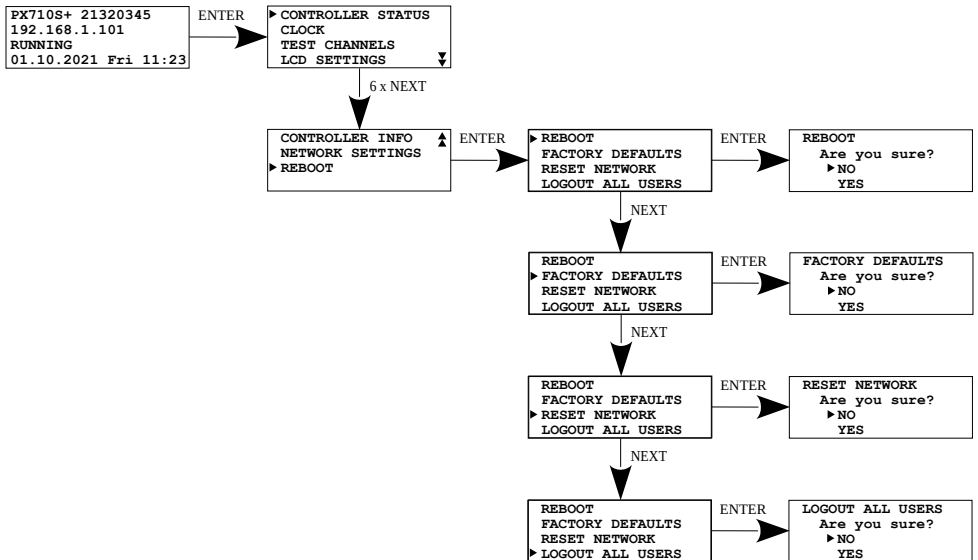

5 Network settings of the controller

The controller stores the static network configuration. It is always used when static addressing mode was selected or in automatic addressing mode, when it was not possible to get the configuration settings from the DHCP server.

The controller can run in one of two modes:

- automatic addressing from DHCP server
- static addressing

In automatic mode (DHCP), after connecting to the network the controller attempts to get the network configuration from a DHCP server (e.g router). Thanks to this, manual configuration of networks parameters is not needed. In

the absence of a DHCP server on the network the controller will operate according to the static configuration (manual setup).

When choosing static addressing, the network parameters configure should be in such a way that the controller is able to operate on the subnet and there is no conflict of IP addresses (devices in the network must have unique IP addresses).

The default network settings of the controller:

- **DHCP:** On
- **IP:** 192.168.0.50
- **Mask:** 255.255.255.0
- **Gate:** 192.168.0.1

If the controller operate in automatic mode in the network and receive IP address from the DHCP server, the detaching of the network cable will result in the loss of IP address and another attempt to get new IP address from the DHCP server. If that fails, the controller switches to operate with a static configuration.

It is recommended to use automatic addressing and connect the controller to the network with a running DHCP server.

Should the controller be connected directly to the computer (no DHCP server), the network parameters must be manually set of both the computer and the controller to operate in one network.

5.1 Change of the computer network configuration

The procedure for changing the computer network configuration varies depending on the operating system. Windows® 10 system is an example here.

Change of the computer network configuration in the Windows® 10 operating system is done in the following:

1. Click **[Start]** 
2. Select **[Settings]** tab

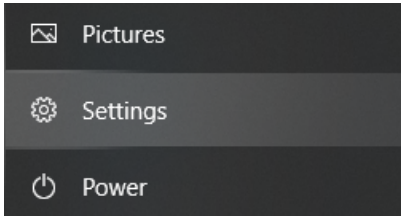

3. Go to **[Network & Internet]** tab

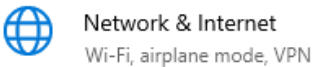

4. Select **[Advanced network settings]**

Advanced network settings

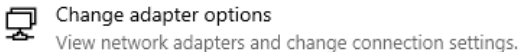

5. Right-click on the appropriate connection, for example it could be **[Ethernet]** and select **[Properties]**

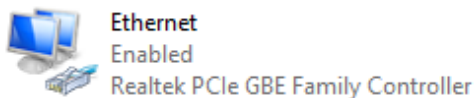

6. In the new window that appears, select **[Internet Protocol Version 4 (TCP/IPv4)]** and then press properties

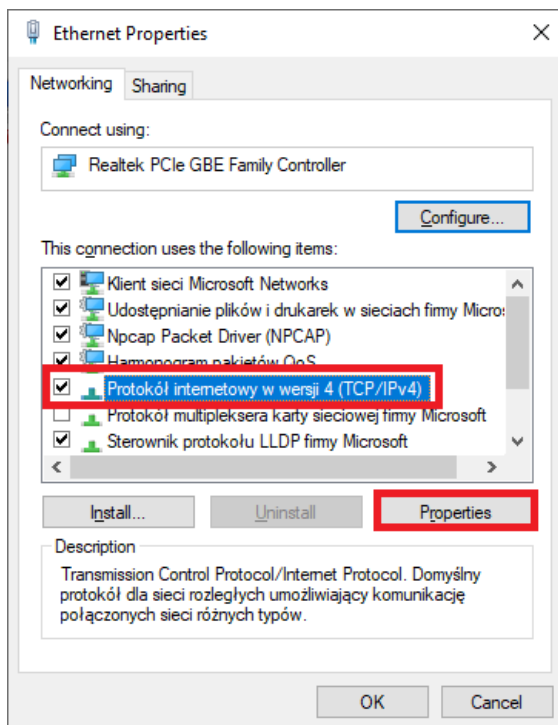

7. In the next window, select [Use the following IP address:]

To connect directly (computer – driver) with a controller that has a default configuration, use the sample settings:

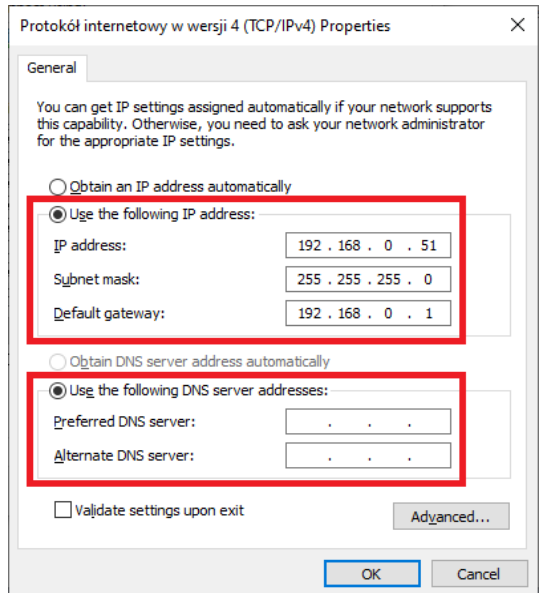

IP address: 192.168.0.51
Subnet mask: 255.255.255.0
Default gateway: 192.168.0.1

5.2 Connecting controller directly to the PC

When connecting the controller directly to a computer it is recommended to use a braided cable. Newer network cards will work both on a braided cable or a non-braided cable, but older ones may require a braided cable.



5.3 Connecting the controller using a router

When connecting the controller to the router, there are two options for network settings. The first of these is the use router with a DHCP server running, the network configuration on all devices in the network is set automatically. The second option is to connect the controller and devices cooperating with it to a switch or router that does not support DHCP server, in this case all devices in the network must have manually configured network settings in such a way that each device operates in the same network and has a unique IP address.

5.3.1 Automatic addressing

Below is a diagram of the operation of devices with the DHCP server running:

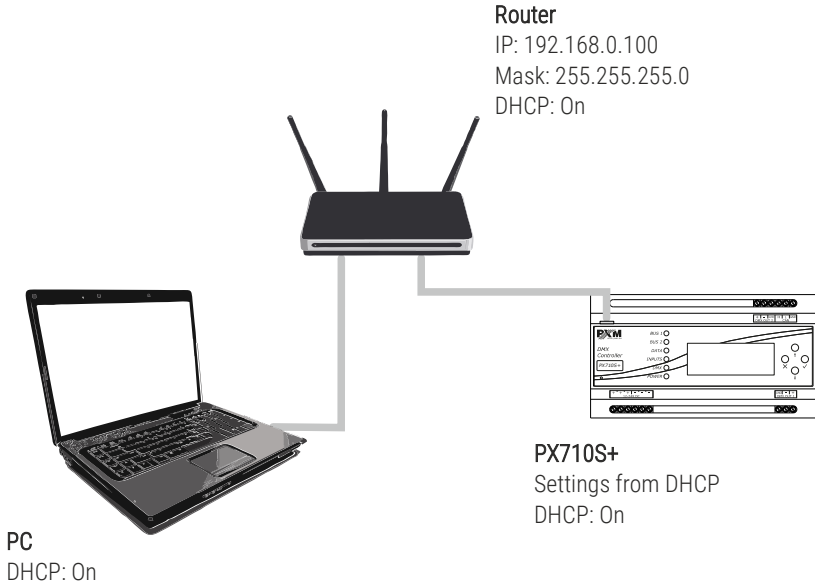

5.3.2 Static addressing

Below is an example diagram of network settings of the controller and devices cooperating with it, in the case when the DHCP server in the network is not running:

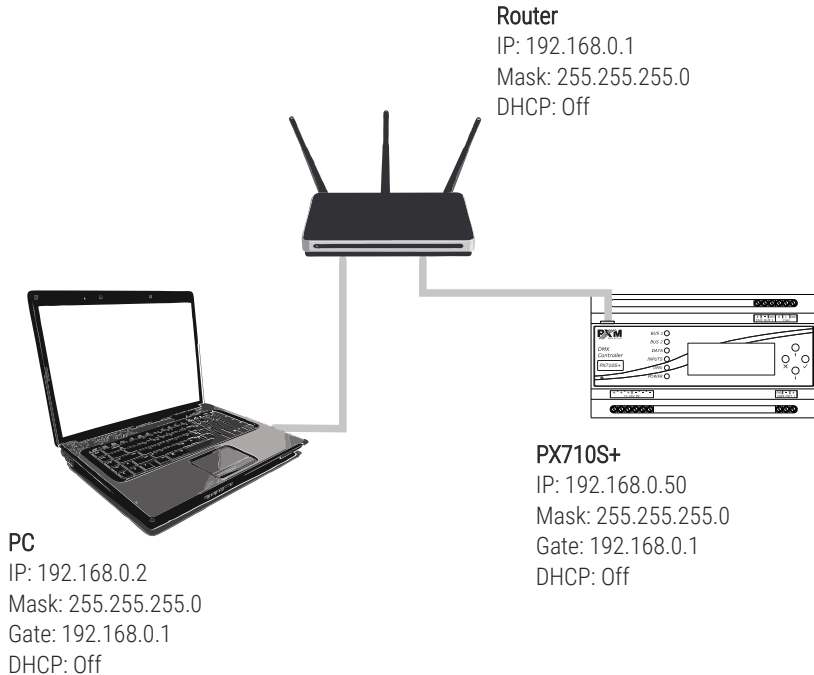

6 Logging into the controller

Logging into the controller is possible from the local network and from external network (Internet). In both cases, the device can be logged in from PC using the PxDesigner program to configure the device. There is always an ADMIN user in the driver, who has the maximum level of permissions. The default password ADMIN user is the serial number of the device. It is

recommended to change the default password and creating user accounts with certain permissions.

6.1 Logging in to the controller in the local network

If the controller and PC are connected to local network and the network address settings are configured correctly, PxDesigner application will automatically search for the driver. When connecting application with the driver, will be required to entry the username and password.

6.2 Remote logging (external network)

The controller allows you to log in to the device from an external network via the internet, for this purpose it should be:

- have an external IP address on the router assigned by the internet provider and be able to establish connection from outside (incoming packets are not blocked by the provider's and router's firewall)
- redirect appropriate ports / port to the IP address of the controller working in the local network (so-called forwarding port):
 - 50000 and 50001 for the PxDesigner application
- unblock selected port in the router's firewall
- the address of the driver / drivers in the local network can not change (the driver must have a static IP address set or the DHCP server must assign the same addresses to the same devices each time)

NOTE! In most routers available on the market, you can set a static IP address by the DHCP server based on the MAC address of the device. For example, for a device with the MAC address 70:B3:D5:EF:B1:60 the IP address 192.168.1.15 will always be assigned by the DHCP server (example below).

Static assignment

IP Address 192.168.1.

MAC address : : : : :

NO.	IP Address	MAC address	Delete
1	192.168.1.15	70:B3:D5:EF:B1:60	<input type="button" value="Delete"/>

Most routers available on the market usually have several parameters in port forwarding options:

- forwarding number
- port or port range for redirection
- the IP address of the device to be redirected to
- protocol type (TCP / UDP or both)
- attach / delete diversion

6.2.1 Logging in via the PxDesigner application

a) one controller works in the local network with the following settings:

- external IP address: 66.77.88.99 (example address)
- IP address: 192.168.1.10
- mask: 255.255.255.0
- target device port: 50000 and 50001
- protocol: TCP or TCP/UDP (in this case option "Both")

Below is the screen of the example setting in the router:

Port range forwarding sets up public services on your network, such as web servers, ftp servers, e-mail servers, and other specialized Internet applications. When you have set up one service, then the communication requests from the Internet to your router's WAN port will be converted to the specified LAN IP address.

NO.	Start port	End port	LAN IP	Protocol	Enable	Delete
1.	50000	50001	192.168.1.10	Both ▼	<input checked="" type="checkbox"/>	<input type="checkbox"/>
2.			192.168.1.	TCP ▼	<input type="checkbox"/>	<input type="checkbox"/>
3.			192.168.1.	TCP ▼	<input type="checkbox"/>	<input type="checkbox"/>
4.			192.168.1.	TCP ▼	<input type="checkbox"/>	<input type="checkbox"/>
5.			192.168.1.	TCP ▼	<input type="checkbox"/>	<input type="checkbox"/>
6.			192.168.1.	TCP ▼	<input type="checkbox"/>	<input type="checkbox"/>
7.			192.168.1.	TCP ▼	<input type="checkbox"/>	<input type="checkbox"/>
8.			192.168.1.	TCP ▼	<input type="checkbox"/>	<input type="checkbox"/>
9.			192.168.1.	TCP ▼	<input type="checkbox"/>	<input type="checkbox"/>
10.			192.168.1.	TCP ▼	<input type="checkbox"/>	<input type="checkbox"/>

Well-known service ports:

If there is no option to set the port range in the router, create two separate rules for each port separately (separately for 50000 and 50001).

If everything is correctly configured to connect to the controller from the (external) internet network, in the application click *Connect*, then select the option *Remote login* and then in the *IP* field enter the IP address of the router (assigned by the internet provider, in this case 66.77.88.99), enter the port numbers 50000 and 50001 in the fields *Port 1* and *Port 2* and then the *Login* with the user's *Password*.

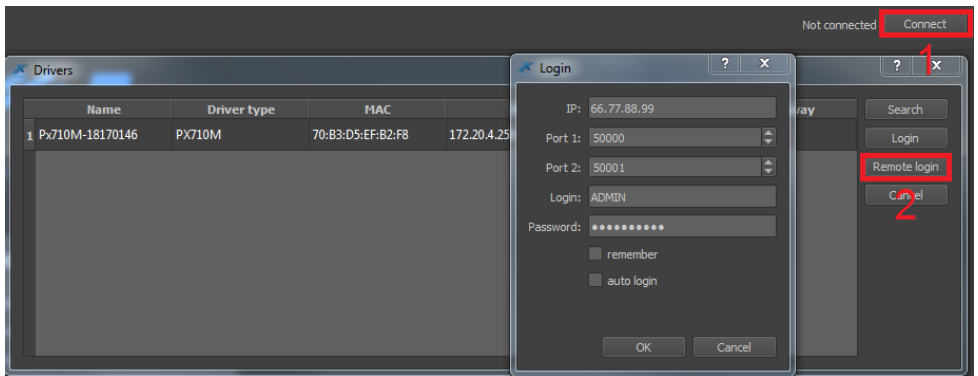

The connection diagram is on the next page.

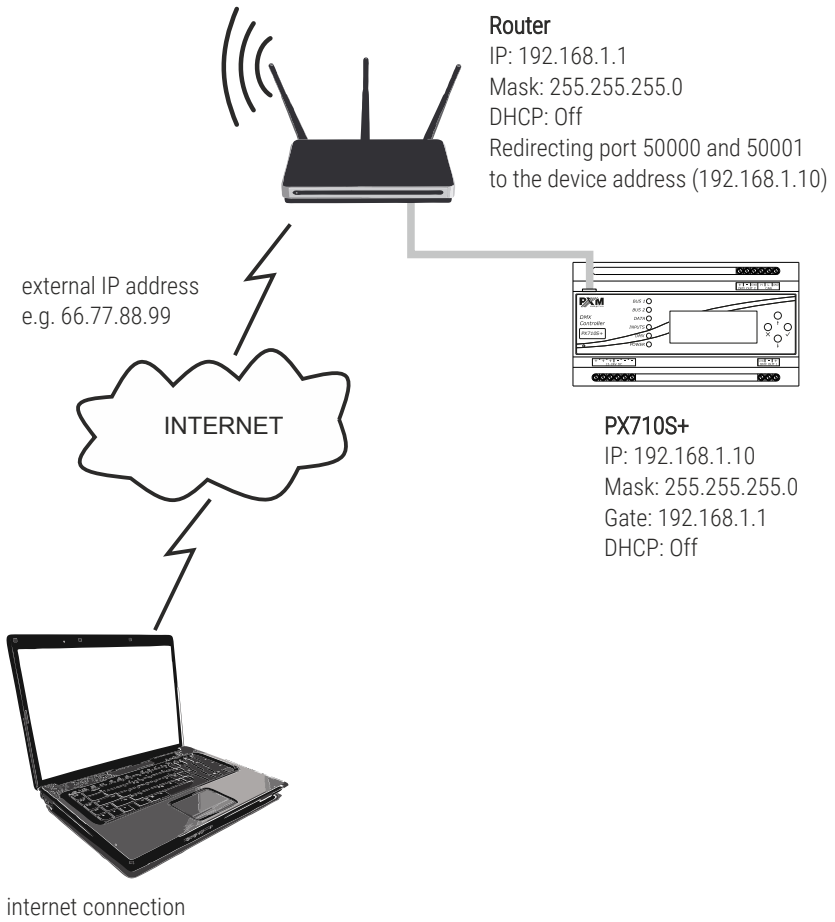

b) more then one controller works in the local network with the following settings:

- external IP address: 66.77.88.99 (example address)
- IP address of the first controller: 192.168.1.10
- IP address of the second controller: 192.168.1.11
- mask: 255.255.255.0
- target device port: 50000 and 50001 for the first controller, 60000 and 60001 for the second controller (for ports 60000 and 60001, the target port in the internal network must be 50000 and 50001 – screen)
- protocol: TCP or TCP/UDP (in this case option “Both”)

Below is the screen of the example setting in the router:

A virtual server defines the mapping from the WAN service port to the LAN server. All requests from the Internet to the designated service port will be redirected to the device specified by the server IP Address.

<input type="checkbox"/>	Service Port	IP Address	Internal Port	Protocol	Status
<input type="checkbox"/>	50000-50001	192.168.1.10	50000-50001	TCP or UDP	Enabled
<input type="checkbox"/>	60000	192.168.1.11	50000	TCP or UDP	Enabled
<input type="checkbox"/>	60001	192.168.1.11	50001	TCP or UDP	Enabled

Add New

Enable Selected

Disable Selected

Delete Selected

Refresh

The connection is exactly the same as in example 1, except that the ports 50000 and 50001 are for the first device, and the 60000 and 60001 are for the second device.

Connection example:

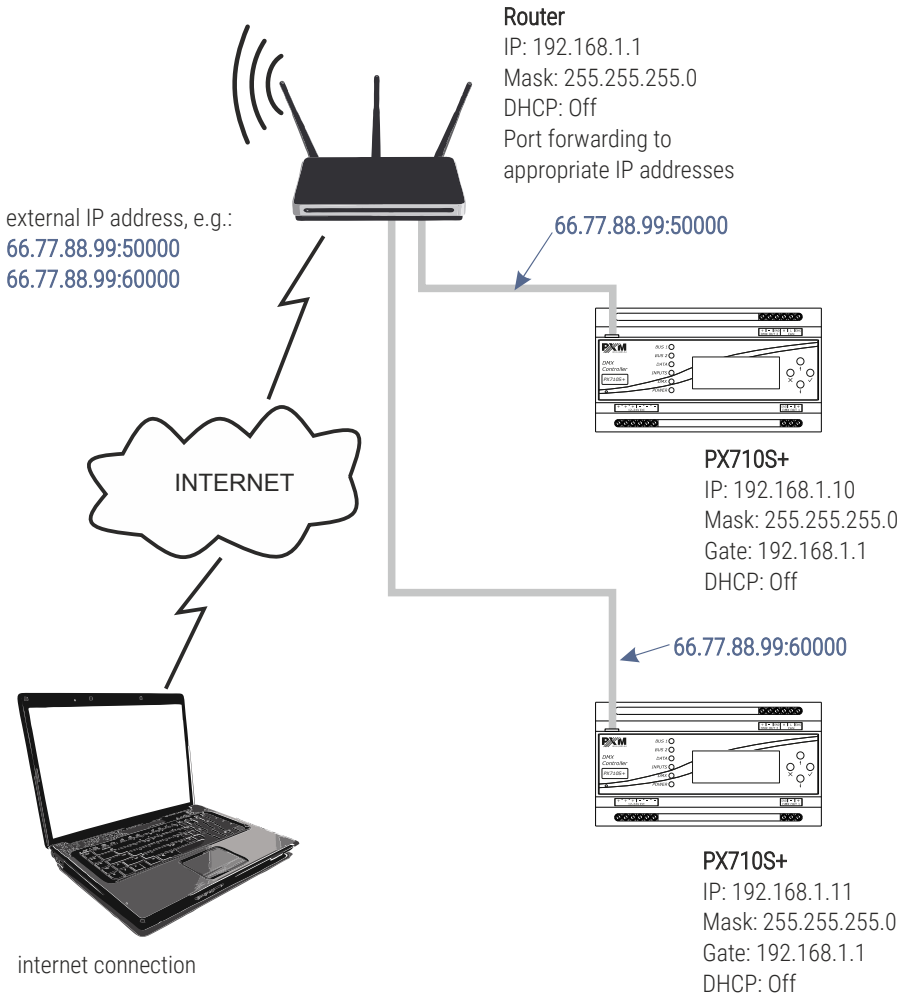

7 Software installation

The manufacturer's website (pxm.pl) includes:

- data sheet,
- controller and PC software manual,
- installers of program cooperating with the controller (PxDesigner),
- file with device firmware update.

NOTE! The firmware update is recommended to be downloaded from the product page, as there is always the latest version of the device firmware update.

7.1 Windows®

The PxDesigner software can be installed on VISTA™, Windows® 7, Windows® 8 or Windows® 10. The procedure for installing the software varies depending on the operating system on the computer. Windows® 7 system is an example here.

Installation is as follows:

1. Open an installation file, click **[Next]** to go to the software installation. The installation file is available for download from the manufacturer's page ([pxm.pl](#)).
2. Select the folder in which the software is to be installed. Confirm your selection by clicking the **[Next]** button.
3. Select components that you want to install and then click **[Next]**.
4. Read the license agreement carefully, if you agree to the terms of this agreement, click **[Next]** to continue installation.
5. Select the start menu in which you want to create a shortcut to the program. You can also rename the directory, then click **[Next]**.
6. The installer will ask again whether you want to install the software, click **[Install]** if you agree.
7. When the window indicating that the installation procedure was successful pops up, click **[Finish]** to exit the installation wizard. If you want to run the program, in the selection window select **[Run PxDesigner now]**.
8. Windows® display a security alert of the system and to be able to use the PxDesigner software, you need to allow access.

NOTE! If you previously installed an older version of PxDesigner, you should uninstall it before installing a newer version.

8 Controller configuration

The driver works in accordance with the configuration uploaded to it, which is created and loaded using the PxDesigner application. The method of creating the configuration is described in the PxDesigner user manual.

NOTE! The PX710S+ cannot work without the PX710M+. The PX710S+ controller should be loaded with the same configuration as for the PX710M+.

9 Live mode

When connected to a computer or a smartphone, the controller can be switched to live mode. In this mode, the controller operates normally in the background, however at the output it sends the currently edited scene or a program step (only for those channels that are covered by the zone to which a scene or program belongs – on other channels it sends the calculated values).

10 Indication lights

The controller is quipped with 6 indicator lights:

Indicator	Action	Function
○ BUS 1		<i>not used in PX710S+</i>
○ BUS 2		
green ● DATA	flashing	receiving data from a PC application
○ INPUTS		<i>not used in PX710S+</i>
blue ● DMX	flashing	the DMX signal is sent
yellow ● POWER	permanent light	the device is running and working in normal mode
	fast flashing	the device is running and has stopped in core mode
	slow flashing	the device is in normal mode, but it has no configuration (at the same time the DMX indicator is blinking), the DMX signal is not transmitted

10.1 RESET button operation and restoring default settings

Action	Reaction
Holding down the button when the power supply is turned on	Switching the device to the core mode
Holding down the button for 2 seconds when the device is in the core mode	Switching the device to the normal operating mode
Holding down the button for 5 seconds when the device is in the core mode	Uploading a configuration from the built-in memory to the device
Holding down the button for 5 seconds in the normal operating mode	Network settings reset – signaled by lighting up the DMX diode and the POWER diode
Holding down the button for 10 seconds in the normal operating mode	Reset of all settings (including the name of the controller), ADMIN account password and erasing the configuration uploaded into the device – these are signaled by all the six indicator diodes illuminating

NOTE! Default parameters are:

IP: 192.168.0.50

Mask: 255.255.255.0

Gate: 192.168.0.100

Device name: Px710S+ [serial number]

ADMIN account password: [serial number]

10.2 Core mode, FTP support

After switching to the core mode (stop in the bootloader), it is possible to connect the controller using the FTP protocol. In this mode, you should always connect to the default static address on the controller from the ADMIN account level, by providing the default password (device serial number) – even if it has been changed.

Direct connection (cable) – assumptions:

- a computer with a stable IP in the same sub-network as the controller
- the controller in the core mode, i.e the PWR diode flashes

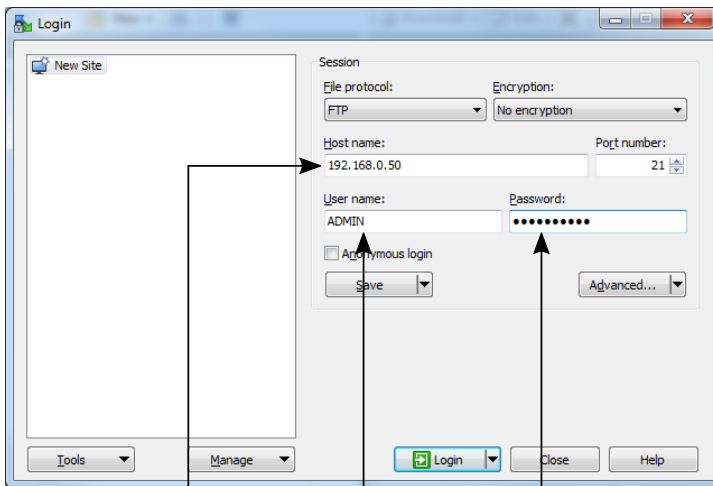

user name: ADMIN

static address of the controller

ADMIN password
(serial number)

NOTE! Recommended FTP client is the free WinSCP program.

The connection to the controller via FTP can be useful when it is not possible to upload the firmware update via the application. Then, replace the "UPGRADE.upg" file in the controller and exit the core mode (by force). The controller will be automatically updated. Using the FTP it is possible to delete the uploaded configuration.

11 Connection scheme

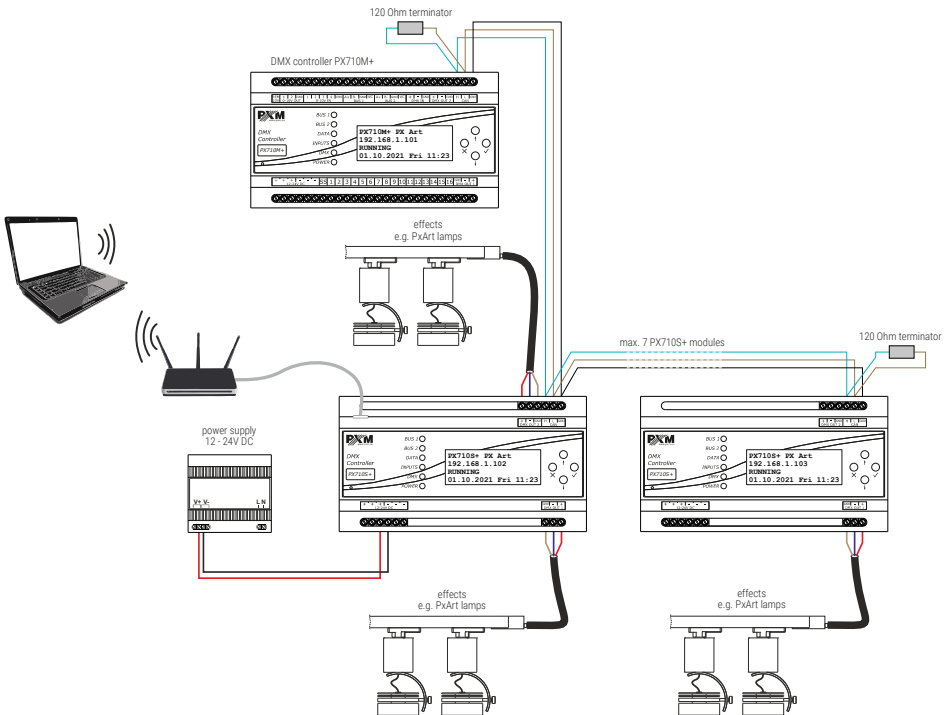

NOTE! A terminator – a 120 Ω resistor should be connected to the first (PX710M+) and the last (PX710S+) device.

12 Dimensions

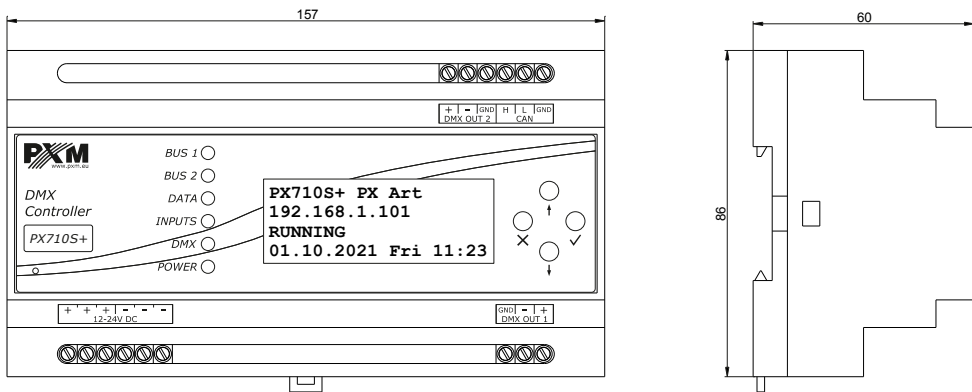

13 Technical data

type	PX710S+
power supply	12 – 24V DC
max. power consumption	2W
DMX output	2 (2 x 512 channels)*
Ethernet port	1
Real Time Clock (RTC)	yes
Modbus	TCP
scenes and programs steps	251000
number of scenes running simultaneously	max. 200
programs	512 (max. 40 simultaneously)
sequences	128
statuses	256
timers	1024

zones	32
users (including ADMIN)	16
weight	0.3kg
dimensions	width: 157mm (9 DIN rail modules) height: 86mm depth: 60mm

* - possibility of expansion using PX710S+ (max. 7)

DECLARATION OF CONFORMITY

PXM Marek Żupnik spółka komandytowa
Podłęże 654, 32-003 Podłęże

we declare that our product:

Product name: DMX Controller Slave

Product code: PX710S+

meets the requirements of the following standards, as well as harmonised standards:

PN-EN IEC 63000:2019-01

EN IEC 63000:2018

PN-EN 61000-4-2:2011

EN 61000-4-2:2009

PN-EN IEC 61000-6-1:2019-03

EN IEC 61000-6-1:2019

PN-EN IEC 61000-6-3:2021-08

EN IEC 61000-6-3:2021

and meets the essential requirements of the following directives:

2011/65/UE **DIRECTIVE OF THE EUROPEAN PARLIAMENT AND OF THE COUNCIL** of 8 June 2011 on the restriction of the use of certain hazardous substances in electrical and electronic equipment
Text with EEA relevance.

2014/30/UE **DIRECTIVE OF THE EUROPEAN PARLIAMENT AND OF THE COUNCIL** of 26 February 2014 on the harmonisation of the laws of the Member States relating to electromagnetic compatibility (recast)
Text with EEA relevance.

Marek Żupnik spółka komandytowa
32-003 Podłęże, Podłęże 654
NIP 677-002-54-53



mgr inż. Marek Żupnik.